

Microtrak and Omnitrak™

Primary Standard Liquid Calibration Systems

Description

Flow Technology's Microtrak and Omnitrak™ positive displacement calibration system provides performance, reliability, and economical benefits of ownership. This liquid calibration system is pneumatically driven and computer-assisted with exceptional accuracy and stability. The Micro/Omnitrak's calibrations are directly traceable to NIST via water draw validation with a total volumetric flow rate measurement uncertainty of approximately $\pm 0.05\%$ at 95% confidence level typical.

The calibrators are manufactured to precise dimensions for liquid flow ranges up to 400 GPM (1,500 LPM). All flow meter technologies with frequency or analog outputs may be calibrated dependent upon responses time.

Calibrations may be performed in a matter of minutes, a vast improvement over competing calibration system methods.

Benefits

- Premium flowmeter accuracy
- NIST traceable calibrations
- Water draw validation
- On site flow meter calibrations
- Minimizes process down time
- Maximizes productivity
- Minimal fluid inventory

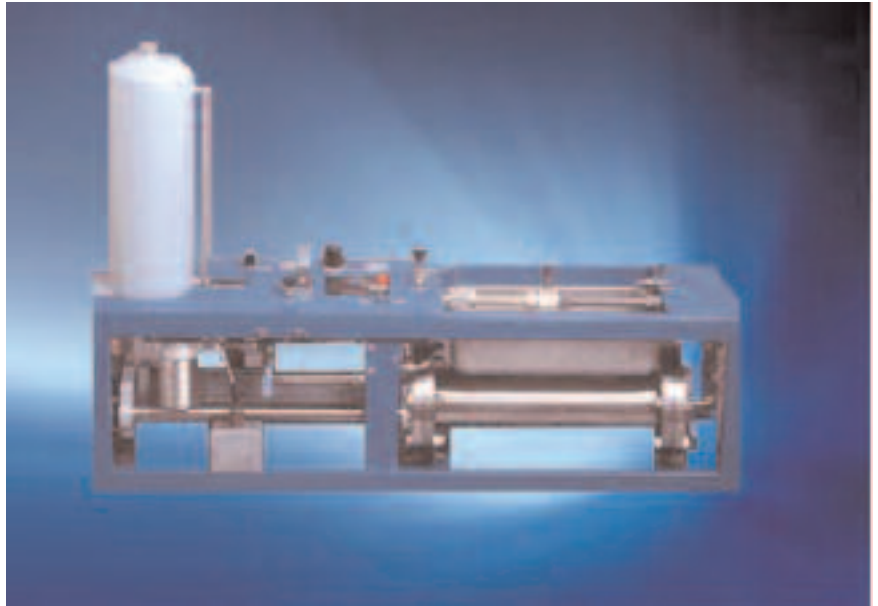

Microtrak™

Primary Standard Liquid Calibration System

Features

- $\pm 0.05\%$ uncertainty of volumetric flow rate measurement (95% C.L.) typical
- Real time temperature compensation
- Performs complete flowmeter calibration in minutes
- Dual Chronometry data acquisition
- Calibrates ALL flowmeter technologies including: Coriolis, Turbine, Orifice, PD, Variable Area, Venturi, and Vortex
- PC-based user interface automatically merges data, performs calculations, saves data, displays data and prints data sheets
- Intuitive, reliable low maintenance system
- Calibration fluid is changed quickly and easily
- Small calibration fluid volume
- Compact size, easy to install
- Flow ranges from 0.001 GPM (0.004 LPM) to 400 GPM (1,500 LPM)

Data Acquisition

The operator adjusts the control valves behind the flowmeter test section for the desired flow rate on both the Microtrak and Omnitrak. An analog dial in the software gives real time flow rates for critical adjustments and data point collection.

Depending upon the flow rates, a complete calibration can be completed in a single stroke of the piston. The software allows the operator to display, analyze, save, and print the data.

Operating costs are minimized since calibrations are performed in minutes, using a small quantity of calibration liquid. Calibrations at different viscosities require only a quick and easily-performed change of calibration liquid. The small physical size of these calibration systems allow installation where space is at a premium. Operating facilities simply require a volume of compressed air and a standard electrical outlet.

Comprehensive operator training is provided by Flow Technology's staff, either on-site or at the factory when a Microtrak or Omnitrak is delivered. Installations worldwide are providing many years of maintenance-free service.

Omnitrak™

Primary Standard Liquid Calibration System

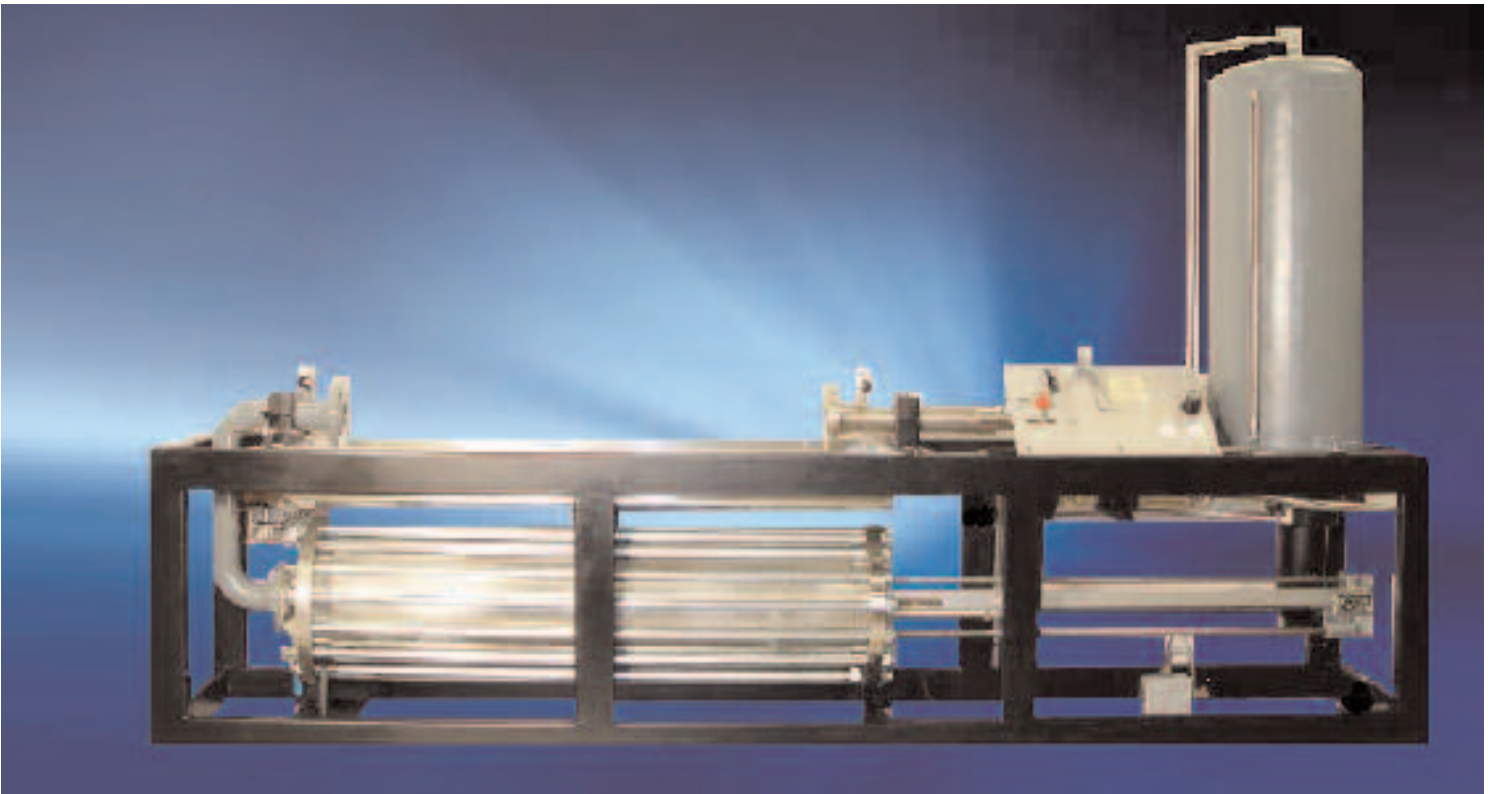

Calware™

Calware™, Flow Technology's flow calibration software for Windows® XP, provides an intuitive user interface. The operator can select calibration units, fluid parameters, convert data, and display results prior to printing. Calware™ logically displays all calibrator controls and parameter settings on a single active screen. Dual Chronometry, a technique pioneered by Flow Technology, insures data integrity. Graph representations of flowmeter non-linearity allow quick analysis of flowmeter performance.

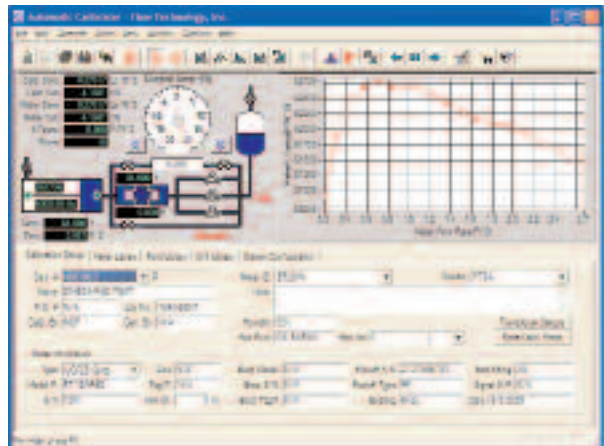

Menu-driven software provides the operator with a variety of curves and plots, which accurately represent the flowmeter's performance during calibration.

How the System Works

Compressed air drives the piston in the precision-honed flow tube at a constant rate, displacing the liquid in the tube and causing it to flow through the test section, which contains the meter being calibrated. The displaced liquid is then stored in the liquid reservoir.

The desired flow rate of the calibration liquid is set by viewing a flow rate readout on the computer screen and adjusting throttle valves. A linear encoder mounted on the piston shaft generates pulses for distance traveled. Each pulse represents an extremely small and precise amount of liquid displaced by the piston, and this pulse train is used to calculate the exact rate of flow. Simultaneously the flowmeter output and measured flow rate are provided by the calibrator. The Dual Chronometry technique ensures that only complete pulses are used for the calculation of flow rate.

The temperature of the calibration liquid can be monitored and used to compensate for density and viscosity changes as data points continue to be acquired throughout the stroke of the piston. At the end of the stroke, the top of the liquid reservoir is pressurized; the pressurized air side of the piston is vented; and the piston returns to the start position. A system of check valves prevents the liquid from flowing back through the meter (being calibrated) during the return stroke, allowing the piston to travel to its start position at a high rate.

At the end of a calibration run, a complete file or a variety of curves can be displayed on the computer screen. These include comparisons with previous calibrations, linearity curves and a host of other methods of displaying the results. The test data may be printed or stored. These options allow calibration trends of a particular meter to be monitored during its lifetime.

The printout shows a table with the following columns: Date, Flow Rate, Meter Reading, and other parameters. The data is organized into several rows, showing various flow rates and corresponding meter readings. The printout also includes a header with the company name 'Flow Technology, Inc.' and a title 'Certificate of Calibration and Performance'.

Calibration data can be compiled in a comprehensive final test report, and a hard copy printed for a permanent record.

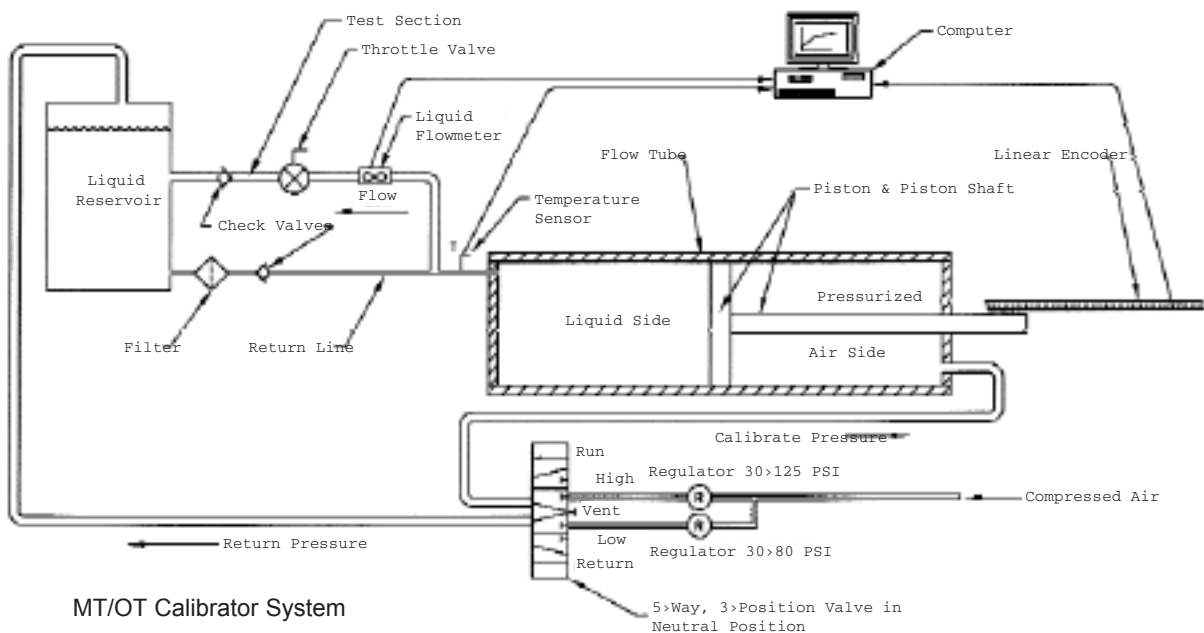

Model Numbering System

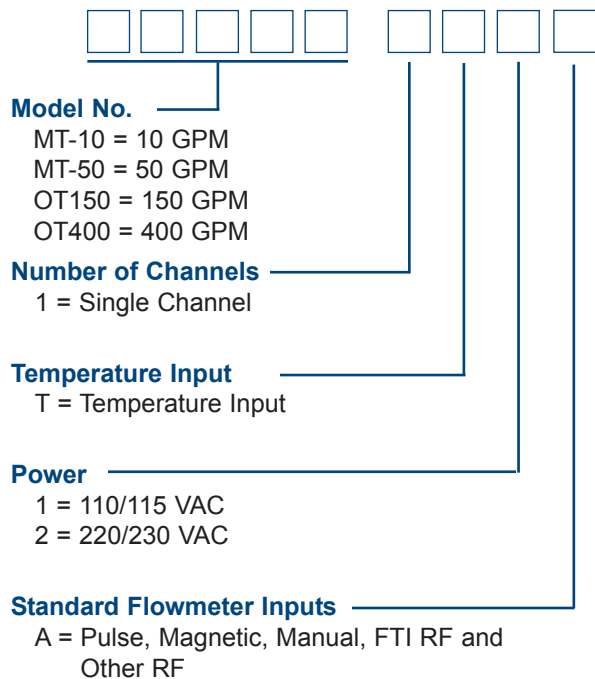

Optional Analog Flowmeter Inputs

(16 bit resolution)

- 0-5 VDC
- 0-10 VDC
- 4-20 mA
- 10-50 mA

Specifications

| | |
|---|---|
| Viscosity Range | 10,000 centistokes maximum |
| Operating Temp. Range | 60° F to 120° F (15° C to 50° C) |
| Operating Pressure | 125 psig (9Kgm/cm ²) maximum |
| Flowmeter Interface | Flowmeter Pulse Outputs |
| <i>Pulse:</i> | 10V p-p maximum, frequency 0–10 kHz |
| <i>Magnetic Pickoff:</i> | Sensitivity 20 mV p-p, 10 V p-p maximum, frequency 0–10 kHz |
| <i>RF Pickoff (FTI):</i> | Inductance 1 mH, resistance 10ohm ±10% |
| <i>RF Pickoff (other):</i> | Inductance 0.35 mH, resistance 3.5ohm ±10% |
| Flowmeter Analog Outputs (See Optional Analog Flowmeter Inputs) | |

Stroke Time at Maximum Flow

- MT-10 = 8.5 seconds
- MT-50 = 2.8 seconds
- OT-150 = 4.1 seconds
- OT-400 = 3.9 seconds

Model Part Numbering System

| Model Number | Flow Ranges GPM (LPM) | Net Dimensions LxWxH (m) | Weight Pounds (kg) | Fluid Capacity Gallons (liters) | Displacement Volume Gallons (liters) |
|--------------|---------------------------------|---|-----------------------|------------------------------------|---|
| MT-10 | 0.001 to 10.0 (0.0038 to 38) | 5' x 1.2' x 4.7' (1.5 x 0.37 x 1.44) | 220 (100) | 3 (12) | 1.5 (6) |
| MT-50 | 0.03 to 50.0 (0.11 to 189.3) | 5' x 1.2' x 4.7' (1.5 x 0.37 x 1.44) | 220 (100) | 5 (20) | 3 (12) |
| OT150 | 0.15 to 150.0 (0.57 to 568) | 11' x 2' x 4.4' (3.4 x 0.6 x 1.35) | 550 (250) | 13 (50) | 7.4 (30) |
| OT400 | 0.4 to 400.0 (1.5 to 1514) | 11' x 2' x 5.9' (3.4 x 0.6 x 1.8) | 1,850 (840) | 35 (130) | 25 (94) |

Specifications are for reference only and are subject to change without notice.

Local Representative:



8930 S. Beck Avenue, Ste 107, Tempe, Arizona 85284 USA
 Tel: (480) 240-3400 • Fax: (480) 240-3401 • Toll Free: 1-800-528-4225
 E-mail: ftimarket@ftimeters.com • Web: www.ftimeters.com

Trademarks are the property of their respective companies.

DB 62071 Rev C © 2012 FTI Flow Technology, Inc. Printed in USA