

FT Series

Turbine Flowmeters for Liquid Applications

Description

Flow Technology's FT Series turbine flowmeters utilize a proven flow measurement technology to provide exceptionally reliable digital outputs. Because of their versatility, these flowmeters are the solution for a wide variety of liquid flow sensing applications. FT Series turbine flowmeters, which range in size from 3/8 inch to 4 inches, offer a high turn-down capability, repeatability of $\pm 0.05\%$ of reading, and excellent speed of response.

The precision, axial-mounted rotor design of the standard turbine flowmeter allows it to operate effectively in flow rates from 0.03 to 1,500 GPM, with the linearity rated at $\pm 0.5\%$ of reading over the normal 10:1 turn-down range. All turbine flowmeters can achieve $\pm 0.1\%$ linearity over the full operating range with linearizing electronics. Typical operating pressures for the standard meters are 5,000 PSIG with custom configurations capable of 30,000 PSIG.

A choice of construction materials can be specified for the turbine flowmeter's housing, rotor, bearings and shaft, including standard stainless steel, and exotic materials for specialized applications.

Features

- Linearity < 0.10% with linearizing electronics
- High turn-down capability, up to 100:1.
- Excellent repeatability, less than +/- 0.05%.
- Typical response time 3-4mS
- Extensive primary standard NIST traceable calibration capability, offering a wide range of fluids, viscosities and flow rates. Accuracy less than +/-0.05% typical
- Standard materials of construction are 316 SS housing and 430F SS rotor. Additional materials available.
- Robust, compact design capably of compliance to severe shock and vibration requirements.
- Standard pressure capabilities up to 5000 PSIG.
- Extreme operating pressures available in custom packages.
- High shock designs available for applications with large hydraulic water hammer effects.
- Custom designs to meet the specific application are routine, not the exception.



FT Series Meters

Specifications

Calibration accuracy	$\pm 0.05\%$ of reading, traceable to NIST
Repeatability	$\pm 0.05\%$ of reading
Linearity	$\pm 0.10\%$ with linearizing electronics
Response time	3-4mS typical
Housing material	316 stainless steel, standard
Rotor material	430F stainless steel, standard
Temperature range	-450 to 750°F, dependent on bearing and pick-off
Operating pressure	Up to 30,000PSIG, dependent on fitting
Ball bearing material	440C stainless steel or equivalent
Journal bearing material	Ceramic, tungsten carbide, graphite
Pick-off's	Modulated carrier and magnetic
Straight Run	10D upstream and 5D downstream minimum
Recommended filtration	Ball bearings: 10 to 100 microns (less filtration with larger sizes) Journal bearings: 75 to 100 microns



Turbine Flow Meter Model Number Selection and Sizing Guidelines

There are 4 major steps in defining a turbine flow meter; these are:

- Choosing the flow meter size
- Bearing selection
- Pick-off selection
- Calibration requirements

These components are interrelated and should be considered as a system to obtain optimum meter performance. Additional options need to be selected that are related more to personal preference. These are end fitting type, materials of construction, and units of measure.

Step 1: Meter size and flow range selection

Detailed below are the considerations that should be taken into account when sizing a flow meter.

- Due to the laws of physics, for optimum results any flow meter (including turbine flow meters) should be operated as high up in their turndown range as possible.
- Clearly, there is a tradeoff between your allowable pressure drop and the size of meter that you can install into your process. In other words, at a given flow rate, a smaller meter will operate higher up in its flow rate range, but will generate a higher pressure drop.
- When selecting the size and flow range of the meter, bearing and pick-off selection must be considered. Ball bearings and RF pick-offs have the least amount of drag, thus provide the widest capable flow range. Journal bearings and magnetic pick-offs create more drag, therefore reducing the turndown capability of the flow meter. Where ever possible an RF pickoff is the ideal choice.
- Ideally, it is beneficial to stay within a 10:1 turndown range. However, the phenomenal repeatability and primary calibration accuracy's enable the Flow Technology turbine to provide outstanding performance over a 100:1 turndown.
- See page 4 for available flow ranges.

Step 2: Pickoff Selection

Reasons to choose a RF pickoff

- Use on FT-24 and smaller meters.
- Use when extended flow range is required.
- Use when real time temperature correction (UVC calibration) is required.
- Flow meter does not require recalibration when pick-off is changed.
- Must be used in conjunction with an amplifier to produce a square wave frequency output.
- Can not be used above an FT-40 size flow meter.

Reasons to choose a Magnetic pickoff

- Use on FT-32 and larger meters.
- Use on cryogenic temperature applications.
- Use when a direct millivolt output is required.
- Flow meter should be recalibrated when pick-off is changed.
- Can be used on smaller flow meters with reduced flow range.

Pick-off Options

- Standard pick-offs have upper operating temperature of 350°F.
- High temperature pick-offs with a 750°F maximum are available.
- Most electronics are available in hazardous area rated enclosures. If system certification is required, pick-offs are available with various ratings.
- Pick-offs are available with built in RTD's when real time temperature correction is required and a UVC calibration is performed on the flow meter. These pick-offs are normally used in conjunction with the Linear Link TCI electronics.
- Amplified pick-offs are available that house circuitry in the pick-off body to provide a high level 0 – 5 volt square wave pulse output. DC power is required.
- See page 6 for pick-off selection options.

Pick-off Mounting Configuration

MS connector

- Pick-offs have two, three or four pin MS connectors.
- Connection to the pick-off is via a mating MS connector with soldered connections and loose wire.
- Typical installation is on test stands or on board applications.
- A junction box or conduit **can not** be attached to this pick-off style.
- This pick-off is used on flow meters that **do not** have 1" MNPT nipples welded to the meter body surrounding the pick-off. Flow meters with threaded end connections typically do not have the 1" nipple.

Flying leads with threaded connection

- Pick-offs have flying leads extending from the potted pick-off body.
- Mechanical connection to the pick-off is via a ½" MNPT thread integral to the top of the pick-off body or the 1" MNPT thread of the flow meter nipple.
- This pick-off style is required when a junction box and rigid or flexible conduit is to be mounted directly to the pick-off body.
- Typical installation is a more industrial environment.
- This threaded body pick-off is used on flow meters that **do not** have 1" MNPT nipples welded to the meter body surrounding the pick-off. A flying lead pick-off with smooth body are used on flow meters that **do** have the 1" MNPT nipple. Flow meters with threaded end connections typically do not have the 1" nipple. Flow meters with flanged end connections typically do have the 1" nipple.

Step 3: Bearing Selection

- Bearings are available in two styles, Ball and Journal Sleeve.
- Ball bearings are manufactured from 440C SS and is the typical choice for lubricating applications.
- Journal Sleeve bearings are available in three different material selections. (Note: The Journal Ceramic bearing is the typical bearing of choice for non-lubricating applications.)
- See page 5 for bearing selection options.

Ball bearings (model # code "A")

- Bearing option to measure lubricating fluids.
- Low frictional drag provides the widest possible flow range.
- Ball bearing set can be replaced in the field.
- 10 to 50 micron filtration required, dependent on meter size.
- Operating temperature range of -450° to 300° F.
- 440C stainless steel materials of construction or equiv.
- Provides exceptional life and rugged construction in clean lubricating applications.

Journal Carbide bearings (model # code "D")

- Bearing option to measure low or non-lubricating fluids.
- Hard bearing material provides long life and rugged construction.
- Less turn down capability than the ball bearing. (valid for all journal bearing options)
- Field replacement of bearing not recommended. (valid for all journal bearing options)
- 75 to 100 micron filtration required. (valid for all journal bearing options)
- Operating temperature range of -100° to 1200° F.
- Tungsten Carbide materials of construction.
- Hard bearing material provides long life and rugged construction.

Journal Graphite bearings (model # code "E")

- Bearing option for corrosive applications.
- Operating temperature range of -100° to 550° F.
- Bearing option to measure low or non-lubricating fluids.
- Materials of construction are epoxy impregnated Carbon Graphite bearing with 316 SS shaft.
- Lubricating property of the graphite allows this bearing to run smoother than the other two journal options, however life of the bearing will be slightly reduced.
- Not recommended for use above FT-32 meter size.

Journal Ceramic bearings (model # code "G")

- Typical bearing option to measure low or non-lubricating fluids.
- Operating temperature range of -100° to 800° F.
- Typical bearing option for more corrosive applications.
- AL₂O₃ (99.5%) Ceramic materials of construction.
- Ceramic material is impervious to most fluids, resists film build up on bearing surface, long life, not as robust as tungsten carbide material.
- Not recommended for use in water above 180° F.

Step 4: Calibration Selection

- Flow Technology has one of the world's largest liquid and gas primary calibration facilities.
- The ability to accurately calibrate a flow meter with trace ability to international standards is one of the fundamental requirements in any flow metering application.
- Flow Technology offers a range of water, solvent, oil, and oil blend calibrations.
- A 10 data point calibration is offered as standard, 20 and 30 point calibrations are offered as options. A higher number of data points will define the calibration curve in more detail. If linearizing electronics will be used a minimum of a 20 point calibration is recommended.
- Viscosity does shift the flow meter calibration curve and should be compensated for.

Application will be at relatively constant temperature and viscosity

- For optimum performance your flow meter should be calibrated close to its operating viscosity. Water at 1 cst and solvent at 1.2 cst viscosity is standard, a specific calibration to simulate the operating viscosity can be specified as an option.

Application will cover a range of operating temperature and viscosity

- If the fluid viscosity or density is changing due to temperature variation, a Universal Viscosity Calibration (UVC) should be used to perform real time temperature correction.
- The viscosity range for the calibration is determined by the minimum fluid viscosity at the maximum operating temperature and the maximum fluid viscosity at the minimum operating temperature.
- See page 5 for calibration options.



FT Series

FT Meter Sizing and End Fittings

Extended Flow Range

Series / Order Code	End Fitting Nominal Inches	ID	10:1 Standard Range		Ball Bearing / RF Pickoff	Ball Bearing / Mag Pickoff	Journal Bearing / RF Pickoff	Journal Bearing / Mag Pickoff	Max GPM	K Factor P/G	Maximum Frequency Approx. Freq.
			Min GPM	Max GPM	Min GPM	Min GPM	Min GPM	Min GPM			
FT 4-6	3/8	0.30	0.25	2.5	0.03	0.10	0.10	0.12	3	48000	2000
FT 4-8	1/2	0.30	0.25	2.5	0.03	0.10	0.10	0.12	3	48000	2000
FT 6-8	1/2	0.37	0.50	5.0	0.05	0.12	0.15	0.20	5	25000	2100
FT 8-8	1/2	0.40	0.75	7.5	0.08	0.16	0.20	0.25	8	16000	2000
FT -08	1/2	0.44	1.00	10.0	0.10	0.20	0.25	0.30	10	12000	2000
FT-10	* 3/4	0.50	1.25	12.5	0.15	0.30	0.30	0.40	15	9600	2000
FT-12	3/4	0.56	2.0	20	0.25	0.50	0.50	0.50	25	6000	2000
FT-16	1	0.86	5.0	50	0.60	1.0	1.0	1.0	60	2400	2000
FT-20	1 1/4	1.00	9.0	90	1.0	1.5	1.0	1.5	100	1300	1950
FT-24	1 1/2	1.32	15.0	150	1.6	2.5	1.6	2.5	160	600	1500
FT-32	2	1.75	22.0	225	2.5	3.5	2.5	3.5	250	350	1300
FT-40	2 1/2	2.22	40.0	400	4.5	5.0	4.5	5.0	450	180	1200
FT-48	3	2.87	65.0	650	N/A	7.5	N/A	7.5	750	75	812
FT-64	4	3.87	125.0	1250	N/A	15	N/A	15	1500	30	625

* AE fitting = 5/8"

Order Code	End Fittings
AE	AN (or MS) external straight threads - 3/8" to 2 1/2 nominal size - 37° flare
NE	NPT external threads - 1/2" to 4 nominal size
HB	Hose Barb - 13 to 51 mm/ 1/2" to 2
WF	Wafer type - serrated surface - 13 to 76 mm/1/2" to 3 nominal size
C1	150# Raised Face Flange
C2	300# Raised Face Flange
C3	600# Raised Face Flange
C4	900# Raised Face Flange
C5	1500# Raised Face Flange
C6	2500# Raised Face Flange
J2	300# Ring Joint Flange
J3	600# Ring Joint Flange
J4	900# Ring Joint Flange
J5	1500# Ring Joint Flange
J6	2500# Ring Joint Flange
T1	Tri-Clamp 1/2" to 3/4
T2	Tri-Clamp 1" to 1 1/2

Part Number Structure

F	T	X	X	X	X	X	X	X	L	X	X	X	X	X	X	X	X
Meter Size				End Fittings		Calibration				Material	Bearing	Pickoff		Optional Designators			

Calibration

Order Code	# Points	Flow Range	Fluid
NW	10 point	normal 10:1 range	in water
NS	10 point	normal 10:1 range	in solvent
NB	10 point	normal 10:1 range	in oil blend
XW	10 point	extended range	in water
XS	10 point	extended range	in solvent
XB	10 point	extended range	in oil blend
TW	20 point	normal 10:1 range	in water
TS	20 point	normal 10:1 range	in solvent
TB	20 point	normal 10:1 range	in oil blend
YW	20 point	extended range	in water
YS	20 point	extended range	in solvent
YB	20 point	extended range	in oil blend
GW	30 point	extended range	in water
GS	30 point	extended range	in solvent
GB	30 point	extended range	in oil blend

Order Code	# Points	Cal Style	# Viscosities
U2	10 points each viscosity	Universal Viscosity Curve	2 Viscosities (specify minimum viscosity & maximum viscosity).
U3	10 points each viscosity	Universal Viscosity Curve	3 Viscosities (specify minimum viscosity & maximum viscosity).

Order Code	# Points	# Pickoffs	Cal Style	Fluid
BW	10 points each direction	1 pickoff	Bi-directional	water
BS	10 points each direction	1 pickoff	Bi-directional	solvent
BB	10 points each direction	1 pickoff	Bi-directional	oil blend

Note: W = Water. S = Solvent. B = Oil blend. The fluid viscosity must be provided with oil blend calibrations

Material & Bearing Selection

Order Code	Housing	Rotor	Bearing Code
E	316 SST	430F SST	A - D - E - G - H
G	316 SST	316 SST	D - E - G
H	316 SST	17-4 PH SST	A - D - E - G - H
N	HAST C	HAST C	E - G

Note: Please contact factory for material codes "G" and "N".

3rd Digit of Calibration

Code	Description
U	To signify required units of measure other than GPM
R	To signify special calibration flow range other than normal 10:1 or extended range
B	To signify both changes in units and special flow range.

Bearing Selection

Order Code	Description
A	Ball Bearings (440 C or equivalent)
D	Carbide Journal (Carbide Shaft & Sleeve)
E	Graphite Journal (Graphite Sleeve, 316 SST Shaft)
G	Ceramic Journal (Ceramic Shaft & Sleeve)

Part Number Structure

F	T	X	X	X	X	X	X	-	L	X	X	X	X	X	X	X
Meter Size				End Fittings			Calibration			Material	Bearing	Pickoff		Optional Designators		

Magnetic and RF Pickoff Selection Selection

Order Code	RF (Modulated Carrier)
-1	MS connector
-5	Flying leads/threaded connection
-L	MS connector, 400° C/750° F max.
-M	Flying leads/threaded connection 400° C/750° F max.
-8	MS connector, 330 µH coil
-9	MS connector, 5/8"-18 thread, 1mH coil
-Y	CSA X-Proof
T1	RTD, MS connector
T5	RTD, flying leads/threaded connection
-X	I.S. approved, MS connector
SS	I.S. approved, flying leads/smooth body
XX	I.S. approved, flying leads/threaded body

Order Code	Magnetic
-2	MS connector
-3	Flying leads/threaded connection
-6	MS connector, 400° C/750° F max
-7	Flying leads/threaded connection 400° C/750° F max.
-Z	CSA X-Proof
T2	RTD, MS connector
T3	RTD, flying leads/threaded connection
-U	I.S. approved, MS connector
PP	I.S. approved, flying leads/smooth body
TT	I.S. approved, flying leads/threaded body

Notes: 1. Maximum temperature rating of pick-offs are 350° F unless otherwise noted.
2. See Amplified Link literature for amplified pick-off codes.

Part Number Structure

F	T	X	X	X	X	X	X	X	X	L	X	X	X	X	X	X	X
Meter Size				End Fittings		Calibration				Material	Bearing	Pickoff		Optional Designators			

Dimensional Drawings

MS / NPT Fitting

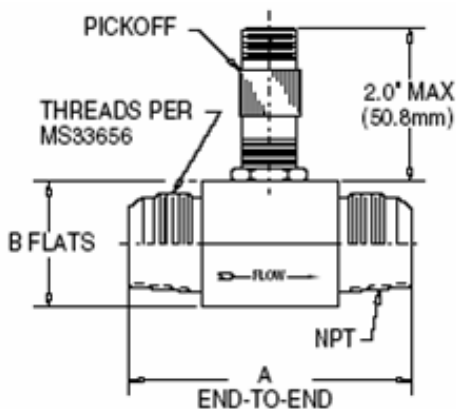

Flange Fittings

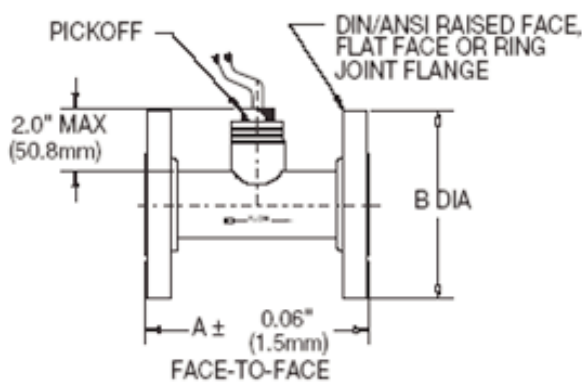

Hose Barb Fitting

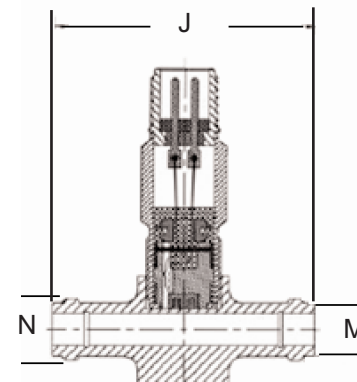

Series	A	B
	in.	in.
FT4-6	2.45	1
FT-8	2.45	1
FT-10	2.72	1.38
FT-12	3.25	1.38
FT-16	3.56	1.63
FT-20	4.06	1.88
FT-24	4.59	2.25
FT-32	6.06	2.75
FT-40	8.9	3.5
FT-48	N/A	N/A
FT-64	N/A	N/A

Series	150#		300#		600#		900#	
	A	B	A	B	A	B	A	B
FT-8	5	3.5	5	3.75	5	3.75	7	4.75
FT-10	5.5	3.88	5.5	4.63	5.5	4.63	5.5	5.13
FT-12	5.5	3.88	5.5	4.63	5.5	4.63	7	5.13
FT-16	5.5	4.25	5.5	4.88	5.5	4.88	8	5.88
FT-20	6	4.63	6	5.25	6	5.25	8	6.25
FT-24	6	5	6	6.13	6	6.13	9	7
FT-32	6.5	6	6.5	6.5	6.5	6.5	9	8.5
FT-40	7	7	7	7.5	9	7.5	9	9.5
FT-48	10	7.5	10	8.25	10	8.25	10	9.5
FT-64	12	9	12	10	12	10.75	12	11.5

Series	J	M	N
	in.	in.	in.
FT4-6	2.45	0.50	0.58
FT-8	2.45	0.50	0.58
FT-10	2.72	0.63	0.70
FT-12	3.25	0.75	0.83
FT-16	3.56	1.00	1.12
FT-20	4.06	1.25	1.37
FT-24	4.59	1.50	1.64
FT-32	6.06	2.00	2.16
FT-40	6.47	2.50	2.67
FT-48	N/A	N/A	N/A
FT-64	N/A	N/A	N/A



8930 S. Beck Avenue, Suite 107, Tempe, Arizona 85284 USA

Tel: (480) 240-3400 • Fax: (480) 240-3401 • Toll Free: 1-800-528-4225

E-mail: ftimarket@ftimeters.com • Web: www.ftimeters.com

DB 68346 Rev D © 2007 FTI Flow Technology, Inc. Printed in USA

