

HS Series

High Shock Turbine Flowmeters

Description

Flow Technology's High Shock turbine flowmeters utilize a proven flow measurement technology to provide exceptionally reliable digital outputs. Because of their versatility, these flowmeters are the solution for a wide variety of liquid flow sensing applications.

The High Shock flowmeter is specifically designed to withstand pressure spikes that create hydraulic shock waves in the fluid when actuators or rams are activated. The downstream end of the meter's housing has a small step, rather than a retaining ring, which prevents internal components from being pushed through by hydraulic shock. The upstream end of the housing includes either a Truark® retaining ring, or in extreme cases, a threaded retaining ring which is screwed into the housing, clamping the internals between the downstream step and the retaining ring. Additionally, the meter's supports are mechanically locked in place so they cannot rotate in the housing.

The High Shock flowmeter's rotor blades are thicker than those found on a standard turbine meter. A radius is machined at the intersection of the blades and rotor hub, eliminating the stress point created by a 90-degree cut. In hydraulic fluid applications requiring the use of ball bearings, a step is located in the upstream bore of the rotor so it cannot be pushed over the bearing.

High Shock meters are available in sizes from 3/8-inch to 2-1/2 inches, and are capable of measuring liquid flow rates from 0.03 to 450 GPM (0.1 to 1,700 LPM). The meters' standard range is 10:1, but can be extended to 100:1.

Applications

Flow Technology's High Shock turbine flowmeters are a rugged flow measurement instrument designed for use in environments with high line pressures, hydraulic shock loads and other extreme conditions. The meter incorporates unique features making it well-suited for use in such applications as hydraulic R&D, production testing, and control of rams and valves in the petroleum industry.



HS Series
Turbine Flowmeters

Operation

A volumetric device that measures the flow of liquids, the turbine flowmeter's design is based on a freely-suspended turbine rotor which is rotated by the flow of fluid through the meter body.

Features

- Designed for environments with high line pressures and hydraulic shock loads
- Utilizes special, reinforced rotor blades
- High turndown capability, up to 100:1
- Excellent speed of response
- Repeatability of $\leq \pm 0.05\%$
- Linearity of $\leq \pm 0.05\%$ of reading over normal 10:1 range for liquid
- Operating pressure determined by end fitting selected
- Liquid flow rates from 0.03 to 450 GPM (0.1 to 1,700 LPM)
- Choice of NPT, MS, SAE 4-Bolt and Dynamic Beam Seal end fittings
- Additional end fittings available as special configurations

Model Numbering System

HS Sizing

5-Digit Series & Size	AE, NE & 62 End Fitting Nominal	DB End Fitting SAE AS 85720/01	Meter ID		Normal Flow Range 10:1				Extended Range						Based on Normal Range NOMINAL K-FACTOR APPROX.						
									Ball Bearings			Journal Bearings						ALL MAX			
									RF MIN	MAG MIN		RF MIN	MAG MIN					GPM	LPM	P/G	P/L
			in.	mm	GPM	LPM	GPM	LPM	GPM	LPM	GPM	LPM	GPM	LPM							
			MIN	MAX	MIN	MAX	MIN	MAX	MIN	MAX	MIN	MAX	MIN	MAX							
HS 4-6	3/8	-06	.30	7.6	.25	2.5	.95	9.5	.03	.11	.10	.38	.10	.38	.12	.45	3	11	48000	12680	2000
HS 4-8	1/2	-07	.30	7.6	.25	2.5	.95	9.5	.03	.11	.10	.38	.10	.38	.12	.45	3	11	48000	12680	2000
HS 6-8	1/2	-07	.37	9.4	.50	5.0	1.9	19	.05	.19	.12	.45	.15	.57	.20	.76	5	19	25000	6600	2100
HS 8-8	1/2	-08	.40	10	.75	7.5	2.8	28	.08	.30	.16	.60	.20	.76	.25	.95	8	30	16000	4200	2000
HS-08	1/2	-09	.44	11	1.00	10.0	3.8	38	.10	.38	.20	.76	.25	.95	.30	1.1	10	38	12000	3170	2000
HS-10	*5/8, 3/4	-10	.50	13	1.25	12.5	4.7	47	.15	.57	.30	1.1	.30	1.1	.40	1.5	15	56	9600	2540	2000
HS-12	3/4	-12	.56	14	2	20	7.6	76	.25	.95	.50	1.9	.50	1.9	.50	1.9	25	94	6000	1580	2000
HS-16	1	-16	.86	22	5	50	19	190	0.6	2.3	1.0	3.8	1.0	3.8	1.0	3.8	60	227	2400	635	2000
HS-20	1-1/4	-20	1.00	25	9	90	34	340	1.0	3.8	1.5	5.7	1.0	3.8	1.5	5.7	100	378	1300	345	1950
HS-24	1-1/2	N/A	1.32	34	15	150	57	570	1.6	6.0	2.5	9.5	1.6	6.0	2.5	9.5	160	605	600	160	1500
HS-32	2	N/A	1.75	44	22	225	85	850	2.5	9.5	3.5	13	2.5	9.5	3.5	13	250	946	350	92	1300
HS-40	2-1/2	N/A	2.22	56	40	400	151	1510	4.5	17	5.0	19	4.5	17	5.0	19	450	1700	180	48	1200

Abbreviations for Units of Measure:

GPM = Gallons per Minute
 LPM = Liters per Minute
 P/G = Pulses per Gallon
 P/L = Pulses per Liter

Black = English (US) Units
 Blue = Metric (SI) Units
 English units in GPM
 Metric units in LPM

End Fittings

AE = AN (or MS) external straight threads, 37° flare
 NE = NPT external threads
 DB = Dynamic Beam Seal, per SAE AS 85720/01
 Note: "DB" fitting available up to size HS-20

62 = SAE Code 62, 4-bolt split flange
 Note: "62" fitting available for HS 4-8 – HS-20

* HS-10 "AE" fitting is 5/8". NE and 62 fittings are 3/4"

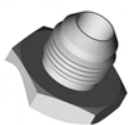

AN (MS)

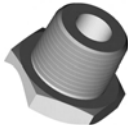

NPT



SAE Code 62



Dynamic Beam Seal

Calibration

CODE DESCRIPTION

Note: W=Water, S=Solvent, B=Oil Blend

Viscosity must be provided with oil blend calibrations "B"

NW	10-point, normal 10:1 range, in water
NS	10-point, normal 10:1 range, in solvent
NB	10-point, normal 10:1 range, in oil blend
XW	10-point, extended range, in water
XS	10-point, extended range, in solvent
XB	10-point, extended range, in oil blend
TW	20-point, normal 10:1 range, in water
TS	20-point, normal 10:1 range, in solvent
TB	20-point, normal 10:1 range, in oil blend
YW	20-point, extended range, in water
YS	20-point, extended range, in solvent
YB	20-point, extended range, in oil blend

U2	Universal Viscosity Curve, 2 Viscosities (specify minimum viscosity & maximum viscosity). 10 points each viscosity
U3	Universal Viscosity Curve, 3 Viscosities (specify minimum viscosity & maximum viscosity). 10 points each viscosity

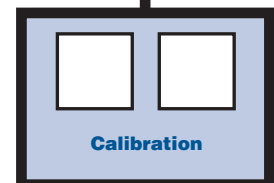
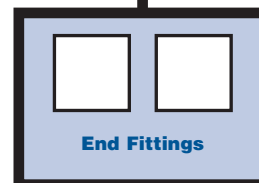

Special

If the full normal 10:1 flow range or the full extended flow range is required and the units of measure are GPM, insert a dash “-” in this location for standard range and units.

If a flow range other than the normal 10:1 or extended flow range, or if units of measure other than GPM are required, insert an “S” in this position. When an “S” is used in this position, the minimum and maximum flow range, as well as the units of measure, must be spelled out.

Liquid

Materials of Construction

MATERIAL CODE	HOUSING	ROTOR
E	316 SST	430F SST

Bearings

Bearing selection will affect flow range. Refer to sizing specification table for correct flow ranges.

- A — Ball Bearings (440 C)
- D — Carbide Journal (Carbide Shaft & Sleeve) — liquid only

Please note:

Highlighted areas indicate standard base price configuration.

Pickoffs

The following is a listing of some of the pickoffs that are available from Flow Technology.

- 1 = Modulated Carrier, MS connector
- 2 = Magnetic, MS connector
- 3 = Magnetic, flying leads/threaded connection
- 5 = Modulated Carrier, flying leads/threaded connection
- 6 = Magnetic, MS connector, 750° F/400° C max.
- 7 = Magnetic, flying leads/threaded connection 750° F/400° C max.
- L = Modulated Carrier, MS connector, 750° F/400° C max.
- M = Modulated Carrier, flying leads/threaded connection 750° F/400° C max.
- T1 = Modulated Carrier w/RTD, MS connector
- T2 = Magnetic w/RTD, MS connector
- T3 = Magnetic w/RTD, flying leads/threaded connection
- T5 = Modulated Carrier w/RTD, flying leads/threaded connection
- X = Modulated Carrier, I.S. approved, MS connector
- XX = Modulated Carrier, I.S. approved, flying leads/threaded body
- U = Magnetic, I.S. approved, MS connector
- TT = Magnetic, I.S. approved, flying leads/threaded body

Notes:

1. Maximum temperature rating of pickoffs are 350° F (177° C) unless otherwise noted.
2. See Amplifier Link literature for amplified pickoff codes.

Optional Designators

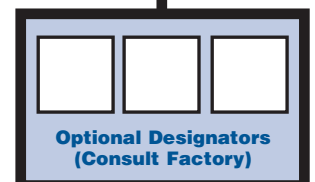
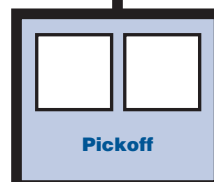
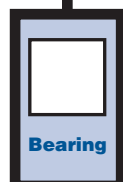
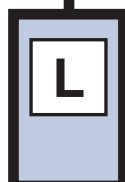
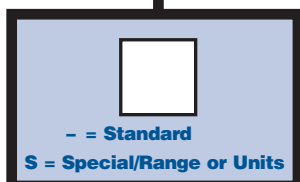

Dimensions

AE, NE or DB Fittings				
Series	A		B	
	in.	mm	in.	mm
HS4-6	2.45	62	1.00	25
HS-8	2.45	62	1.00	25
HS-10	2.72	69	1.38	35
HS-12	3.25	83	1.38	35
HS-16	3.56	90	1.63	41
HS-20	4.06	103	1.88	48
HS-24	4.59	117	2.25	57
HS-32	6.06	154	2.75	70
HS-40	8.90	226	3.50	89

Code 62 Fittings				
Series	A		B	
	in.	mm	in.	mm
HS-8	4.64	118	1.25	32
HS-10	5.13	130	1.63	41
HS-12	5.13	130	1.63	41
HS-16	5.63	143	1.88	48
HS-20	5.63	143	2.13	54
HS-24	6.63	168	2.50	64
HS-32	7.63	194	3.13	80

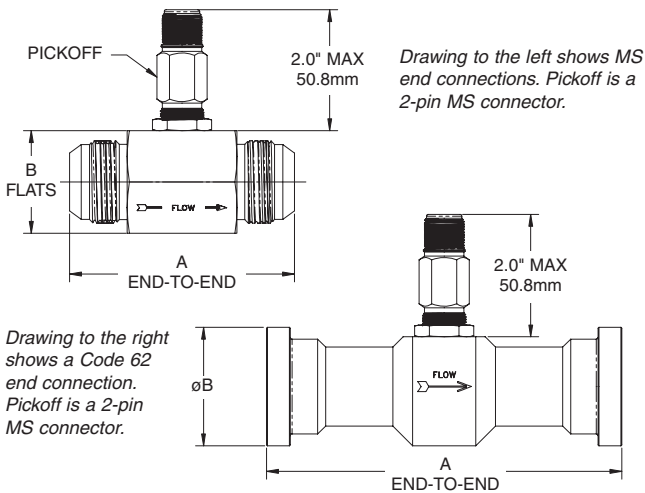

Specifications

Materials of Construction

Standard	316 SST Housing 430F SST Rotor 440 C Ball Bearings Stainless steel all other wetted parts
----------	--

Operating Temperature Range

Defined by pickoff and bearing selection

Bearing Type

Temperature Limits:

440 C stainless steel ball bearings	-450° F to +300° F (-270° C to +150° C)
-------------------------------------	---

Note: Not recommended for water service.

Tungsten carbide journal bearings	-100° F to +1,200° F (-75° C to +650° C)
-----------------------------------	--

Pickoff Type

Temperature Limits:

Magnetic Output:	-430° F to +350° F (-260° C to +177° C) 10 mV min.
------------------	---

High Temp. Magnetic Output:	-430° F to +750° F (-260° C to +400° C) 10 mV min.
-----------------------------	---

Modulated Carrier (RF)	-300° F to +350° F (-185° C to +177° C)
------------------------	---

High Temp. (RF)	Up to 750° F (400° C)
-----------------	-----------------------

Pickoff Electronic Connections

MS Connector	
2-pin, standard pickoff:	15-89515-101
3-pin, amplified pickoff:	15-89515-102
4-pin, pickoff with RTD:	15-93825-01

Threaded Connection with Leads	
Junction Box with Terminal:	73-31836-105

Operating Pressure Range

Defined by end connection

Filtration Recommendations

Ball Bearings	10 micron to 100 micron (with less filtration for large sizes)
Journal Bearings	100 micron

Performance Specifications

Performance specifications are based on a viscosity of 1.2 centistokes using ball bearings.

Calibration Accuracy $\leq \pm 0.05\%$ of reading (accuracy of primary flow calibration standard directly traceable to NIST)

Repeatability $\leq \pm 0.05\%$ of reading

Linearity $\leq \pm 0.5\%$ of reading over the normal 10:1 flow range

$\pm 0.1\%$ of reading with linearizing electronics

Pressure Drop Less than 700 mBAR (10 psid) at maximum 10:1 flow range

Dynamic Response Less than 10 ms response to a step input change of flow rate

Specifications are for reference only and are subject to change without notice.

Diagrams

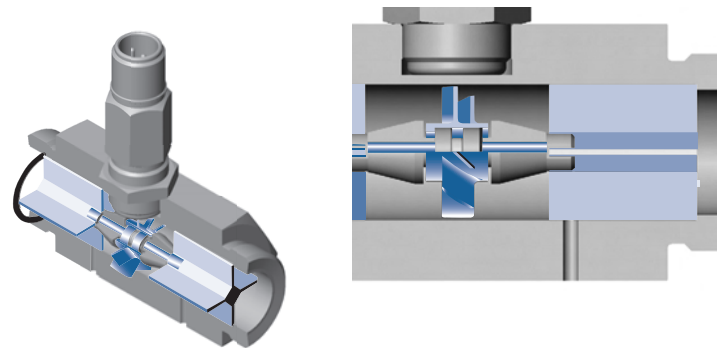

Local Representative:



8930 S. Beck Avenue, Suite 107, Tempe, Arizona 85284 USA
Tel: (480) 240-3400 • Fax: (480) 240-3401 • Toll Free: 1-800-528-4225
E-mail: ftimarket@ftimeters.com • Web: www.ftimeters.com

DB 65107 Rev D © 2008 FTI Flow Technology, Inc. Printed in USA